



Shenzhen Mingqi Photoelectric Co., Ltd.

PRODUCT SPECIFICATION **FOR LCD MODULE**

Revision: 00

Model No: MQHH35

Module Type: LCD+PLZ+IC+FPC

APPROVED SIGNATURE

- Approved Product Specification only
- Approved Product Specification and Samples

<u>Prepared By</u>	<u>Checked By</u>	<u>Approved By</u>



Shenzhen Mingqi Photoelectric Co., Ltd.

Contents

1. General Description	3
2. Physical Features	3
3. Mechanical Specification	3
4. Outline Dimension	4
5. Absolute Maximum Ratings	5
6. Electrical Characteristics	5
7. Module Function Description	6
8. Electro-Optical Characteristics	12
9. Reliability	13
10. Specification of Quality Assurance	14
11. Records Of Version	22



1. General Description

T35P150 is a color active matrix thin film transistor(TFT) liquid crystal display (LCD) that uses amorphous silicon TFT as a switching device. It is a transfective type display. This TFT LCD has a 3.5 inch diagonally measured active display area with (640 horizontal by 480 vertical pixel) resolution.

2. Physical Features

Display Mode	TFT-LCD Module
	Active matrix TFT, Transfective type
Display Format	RGB Vertical Stripe
Input Data	RGB666 input
Driver IC	ST7263
Display Mode	Normally White

3. Mechanical Specification

Item	Contents	Unit
Module size (H×V×D)	86.00 × 66.20 × 0.72	mm
Number of dots	640(RGB) × 480	pixel
Active area (H×V)	71.04 × 53.28	mm
Pixel pitch(W×H)	0.111(H)×0.111(V)	mm



4. Outline Dimension





5. Absolute Maximum Ratings

Item	Symbol	Min	Max	Unit	Remark
Supply voltage	VDD	-0.3	4.0	V	
Operating temperature	TOPR	-20	70	°C	
Storage temperature	TSTR	-30	80	°C	
Humidity	---	---	90	%RH	

6. Electrical Characteristics

T=25° C

Item		Symbol	Rating			Unit	Remark
			Min	Typ	Max		
LCM Supply voltage		VDD	2.5	3.3	3.6	V	
Input Voltage	L level	VIL	0	---	0.3*VDD	V	
	H level	VIH	0.7*VDD	---	VDD	V	
Output Voltage	L level	VOL	0	---	0.2*VDD	V	
	H level	VOH	0.8*VDD	---	VDD	V	
LCD Drive Current		Ivdd	---	57	---	mA	VDD=3.3V



7. Module Function Description

7-1. Block Diagram Of LCM

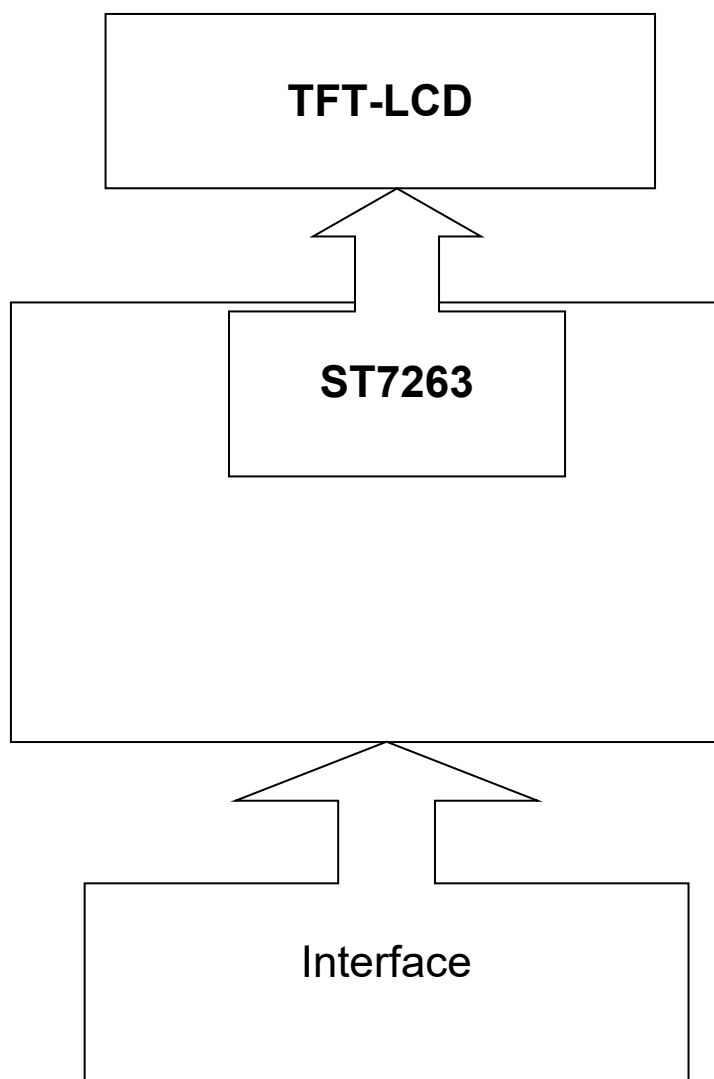



Shenzhen Mingqi Photoelectric Co., Ltd.

7-2. Pin Description

PIN NO.	Symbol	I/O	Description
1	NC	--	No connect
2	VDD	P	Power for LCM
3	GND	P	Ground
4	TP_VDD	P	Power for CTP (Unused)
5	TP_GND	P	Ground
6	TP_SCL	I	CTP I2C Clock (Unused)
7	TP_SDA	I/O	CTP I2C Data (Unused)
8	TP_INT	O	CTP Interrupt Pin (Unused)
9	TP_RESET	I	CTP Reset Pin (Unused)
10	GND	P	Ground
11	R5	I	Red data
12	R4	I	Red data
13	R3	I	Red data
14	R2	I	Red data
15	R1	I	Red data
16	R0	I	Red data
17	G5	I	Green data
18	G4	I	Green data
19	G3	I	Green data
20	G2	I	Green data
21	G1	I	Green data
22	G0	I	Green data
23	GND	P	Ground
24	DE	I	Data enable
25	VSYNC	I	Frame synchronizing signal for RGB interface
26	HSYNC	I	Line synchronizing signal for RGB interface
27	DCLK	I	Pixel clock
28	GND	P	Ground
29	B5	I	Blue data
30	B4	I	Blue data
31	B3	I	Blue data
32	B2	I	Blue data
33	B1	I	Blue data
34	B0	I	Blue data
35	GND	P	Ground
36	RESET	I	LCM Reset pin
37	CS	I	Chip select input pin ("Low" enable).
38	SDA	I/O	Serial interface data
39	SCL	I	Serial interface clock
40	DISP	I	DISP=H, Normal Display DISP=L, Standby mode



7-3. RGB Interface Characteristics

DC Electrical Characteristics (PVDD=VDD=VDDI= 3.3V, AGND= 0V, TA=25°C, Bare Chip)

Item	Symbol	Min.	Typ.	Max.	Unit	Conditions
CLK Pulse Duty	T _{cw}	40	50	60	%	
VSYNC Setup Time	T _{vst}	10	-	-	ns	
VSYNC Hold Time	T _{vhd}	10	-	-	ns	
HSYNC Setup Time	T _{hst}	10	-	-	ns	
HSYNC Hold Time	T _{hhd}	10	-	-	ns	
Data Setup Time	T _{dsu}	10	-	-	ns	
Data Hold Time	T _{dhd}	10	-	-	ns	
DE Setup Time	T _{ddest}	10	-	-	ns	
DE Hold Time	T _{ddehd}	10	-	-	ns	

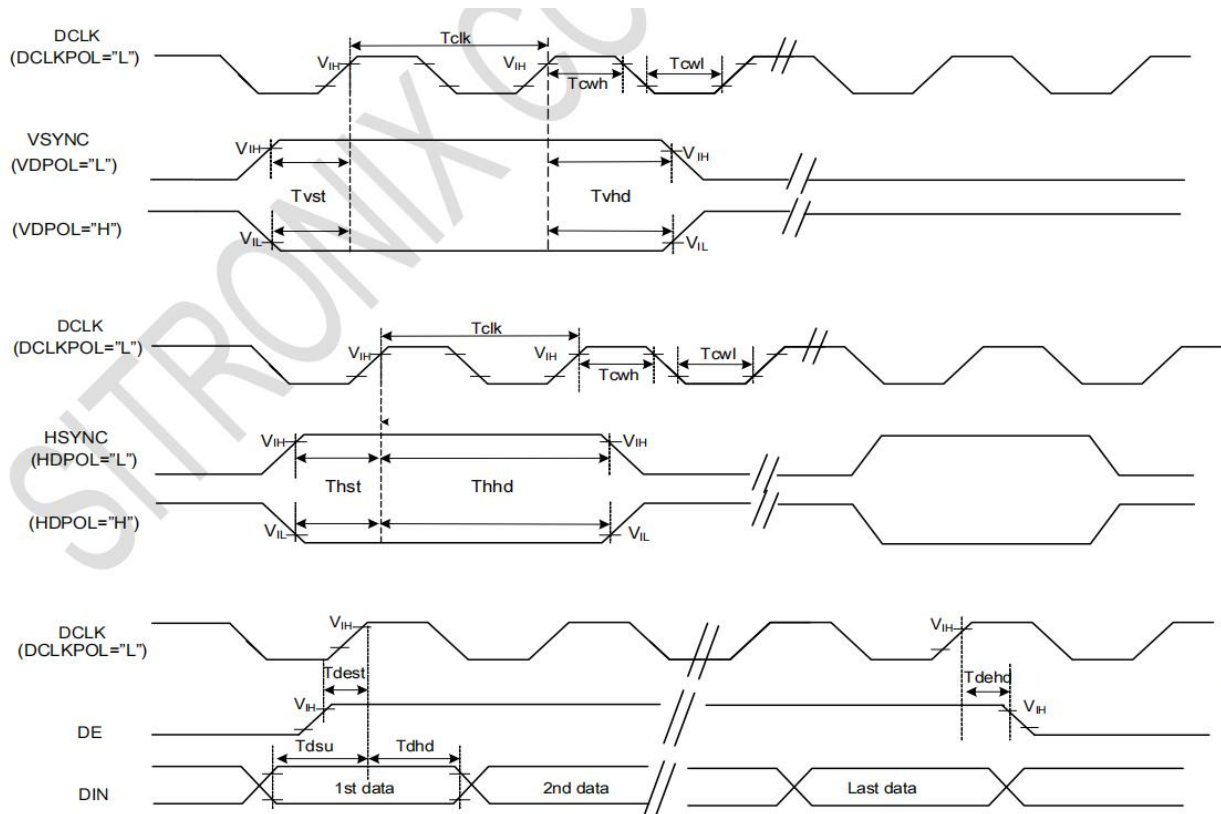



7.4.SPI(3 Line) Interface Characteristics

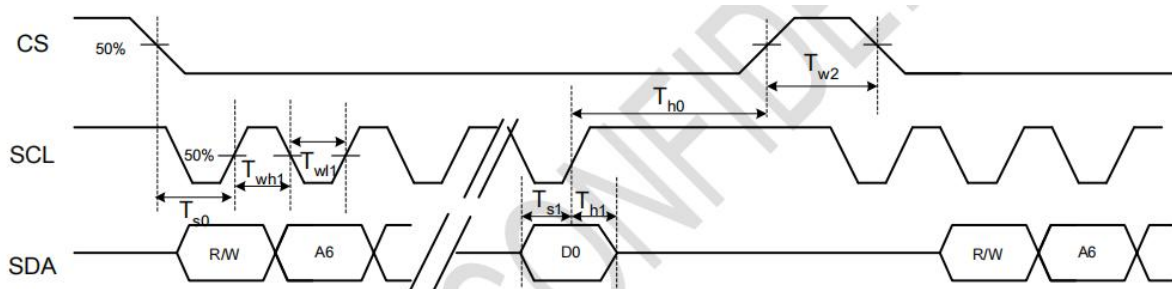

DC Electrical Characteristics (PVDD=VDD=VDDI= 3.3V, AGND= 0V, TA=25°C, Bare Chip)

Item	Symbol	Min.	Typ.	Max.	Unit	Conditions
CS Input Setup Time	T_{s0}	50	-	-	ns	
Serial Data Input Setup Time	T_{s1}	50	-	-	ns	
CS Input Hold Time	T_{h0}	50	-	-	ns	
Serial Data Input Hold Time	T_{h1}	50	-	-	ns	
SCL Write Pulse High Width	T_{wh1}	50	-	2000	ns	
SCL Write Pulse Low Width	T_{wl1}	50	-	2000	ns	
SCL Read Pulse High Width	T_{rh1}	300	-	2000	ns	
SCL Read Pulse Low Width	T_{rl1}	300	-	2000	ns	
CS Pulse High Width	T_{w2}	400	-	-	ns	



7.5. Reset Timing

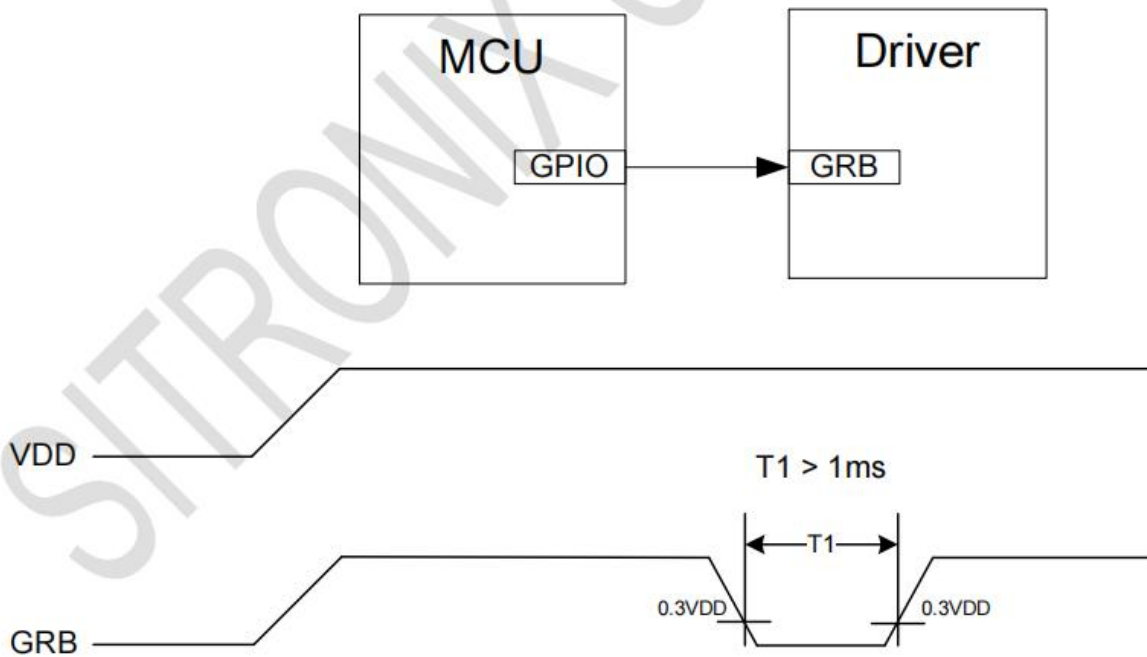

7.6. Power On/Off Timing

Power On

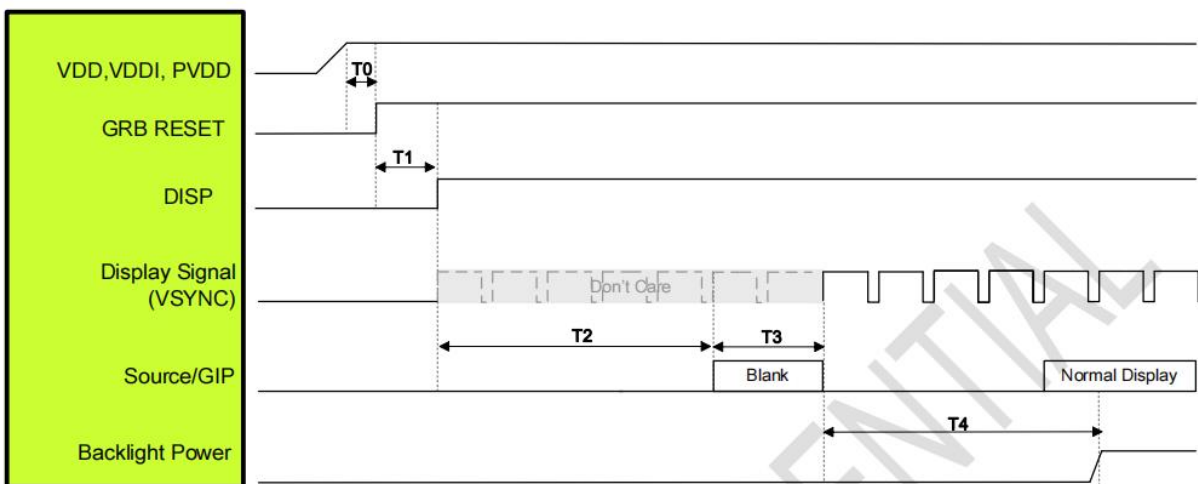



Shenzhen Mingqi Photoelectric Co., Ltd.

Symbol	Description	Time	Unit
T0	System power stability to GRB RESET signal	≥1	ms
T1	GRB RESET= "High" to DISP="High"	≥10	ms
T2	DISP="High" to Source/GIP scan blank	85	ms
T3	IC scan blanking signal	≥33	ms
T4	Display signal input to Backlight power on (base on Display Signal Frame Rate 60Hz)	≥100	ms

Note: 1. When DISP pull "H" or "L", IC will execute the internal power on or power off procedures .Please be careful about the timing of DISP and do not interrupt it during power on or power off procedure, otherwise unexpected errors will occur.

2. RGB interface Display signal: DCLK; VSYNC; HSYNC; DE; DR[7:0]; DG[7:0]; DB[7:0]

Power Off

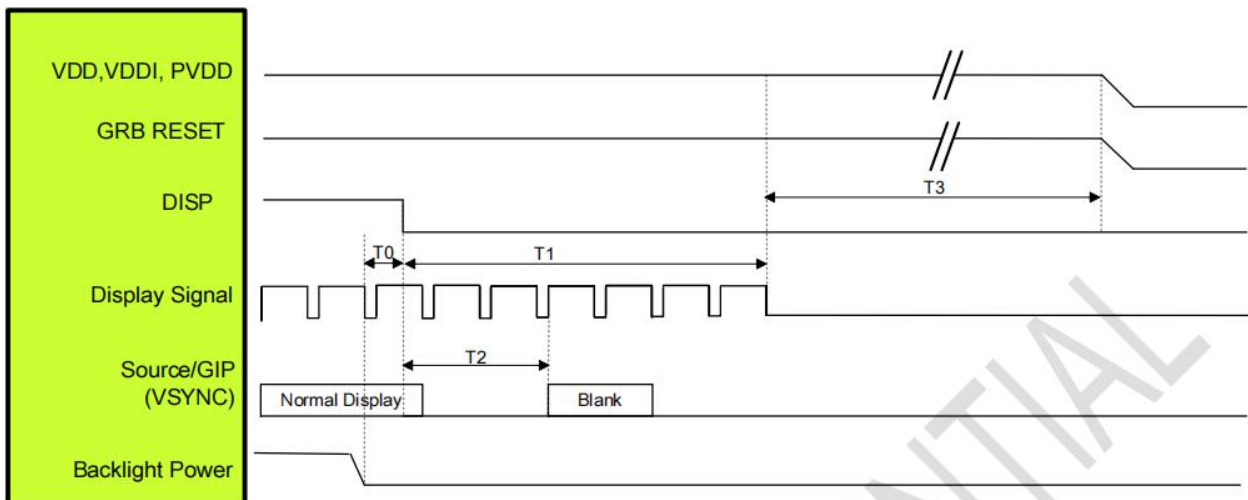

Symbol	Description	Time	Unit
T0	Backlight Power off to DISP="Low"	≥1	ms
T1	DISP="Low" to IC internal voltage discharge complete	≥100	ms
T2	DISP="Low" to Source/GIP scan blank (base on Display Signal Frame Rate 60Hz)	≤50	ms
T3	IC internal voltage discharge is completed to VDD/VDDI/PVDD off	≥0	ms

Note: 1. When DISP pull "H" or "L", IC will execute the internal power on or power off procedures .Please be careful about the timing of DISP and do not interrupt it during power on or power off procedure, otherwise unexpected errors will occur.

2. RGB interface Display signal: DCLK; VSYNC; HSYNC; DE; DR[7:0]; DG[7:0]; DB[7:0]



8. Electro-Optical Characteristics

T=25° C

Item	Symbol	Condition	Min.	Typ.	Max.	Unit	Remark
Response time	Tr +Tf	$\theta_x = \theta_y = 0$	---	5	7	ms	
Contrast Ratio	CR		---	15	---	---	Note 2,4
Viewing angle	θ_T	$CR \geq 10$	---	60	---	Deg.	Note 3
	θ_B		---	60	---		
	θ_L		---	60	---		
	θ_R		---	60	---		
Color Chromaticity	White	x	-0.03	TBD	+0.03	---	Note 4
		y		TBD		---	
	Red	x		TBD		---	
		y		TBD		---	
	Green	x		TBD		---	
		y		TBD		---	
	Blue	x		TBD		---	
		y		TBD		---	
Color gamut	S%		---	7	---	%	

Note (2) Definition of Contrast Ratio(CR):measured at the center point of panel

$$CR = \frac{\text{Luminance with all pixels white}}{\text{Luminance with all pixels black}}$$

Note (3) Definition of Viewing Angle:

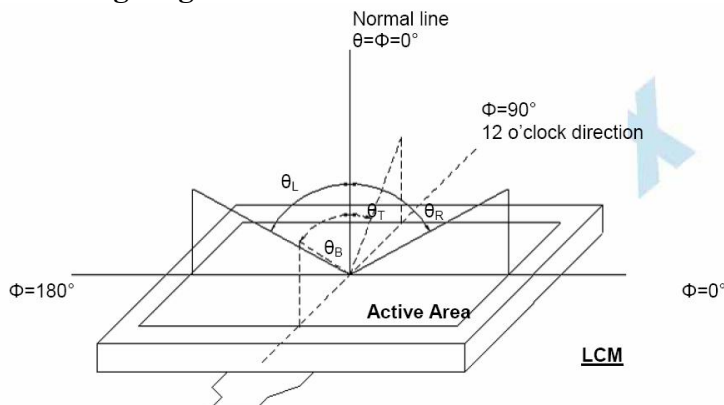

Note(4) Optical Test Instrument:BM-7 (Distance:500mm;Field=1°)



9. Reliability

ITEM	CONDITIONS	CRITERION
OPERATING TEMPERATURE	HIGH TEMPERATURE +70°C 48HRS	NO DEFECT IN DISPLAYING AND OPERATIONAL FUNCTION
	LOW TEMPERATURE -20°C 48HRS	
STORAGE TEMPERATURE	HIGH TEMPERATURE +80°C 48HRS	NO DEFECT IN DISPLAYING AND OPERATIONAL FUNCTION
	LOW TEMPERATURE -30°C 48HRS	
HUMIDITY	60°C 90%RH 48HRS	NO DEFECT IN DISPLAYING AND OPERATIONAL FUNCTION

Note: The need to restore at room temperature for 2 hours after the test.



10. Specification of Quality Assurance

INSPECTION CRITERION

1. Inspection conditions is as follows:

- (1) Viewing distance is approximately 25 ~ 30 cm
- (2) Viewing angle is normal to the LCD panel as Fig _1(30°)
- (3) Ambient temperature is approximately $25 \pm 5^{\circ}\text{C}$
- (4) Ambient humidity is $60 \pm 5\% \text{ RH}$
- (5) Ambient luminance is from 300 ~ 500 Lux.
- (6) Input signal timing should be typical value.
- (7) Mura & Light leakage inspection at ND-Filter 5%

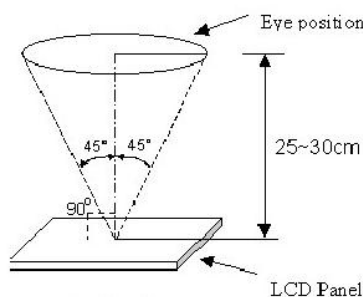

Fig _1

2. Test method: According to MIL-STD105E. General Inspection Level II take a single time.

The defects classify of AQL as following:

Major defect: AQL = 0.65

Minor defect: AQL = 1.5

Total defects: AQL = 1.5

Major defects (MA): A major defect refers to a defect that may substantially degrade usability for product applications, including all functional defects (such as no display, abnormal display, open or missing segment, short circuit, missing component), outline dimension beyond the drawing, progressive defects and those affecting reliability.

Minor defects (MI): A minor defect refers to a defect which is not considered to be able to substantially degrade the product application or a defect that deviates from existing standards almost unrelated to the effective use of the product or its operation, such as black spot, white spot, bright spot, pinhole, black line, white line, contrast variation, glass defect, polarizer defect, etc.

3. Non-conforming Analysis & Deal With Manners

3.1 Non-conforming Analysis:

3.1.1 Purchaser should supply the detail data of non-conforming sample and the non-conforming.

3.1.2 After accepting the detail data from purchaser, the analysis of non-conforming should be finished in two weeks.

3.1.3 If supplier can not finish analysis on time, must announce purchaser before 3 days.

3.2 Disposition of non-conforming:

3.2.1 If find any product defect of supplier during assembly time, supplier must change the good product for every defect after recognition.

3.2.2 Both supplier and customer should analyze the reason and discuss the disposition of non-conforming when the reason of nonconforming is not sure.



Shenzhen Mingqi Photoelectric Co., Ltd.

4. Inspection Criteria

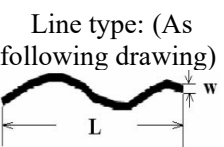
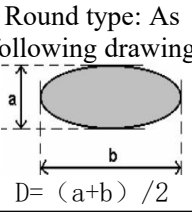
NO	Item	Criterion		AQL												
01	Electrical Testing	1.1 Missing vertical, horizontal segment, segment contrast defect. 1.2 Missing character, dot or icon. 1.3 Display malfunction. 1.4 No function or no display. 1.5 Current consumption exceeds product specifications. 1.6 LCD viewing angle defect. 1.7 Mixed product types. 1.8 Flicker 1.9 Touch Panel: no touch, bad touch		0.65												
02	Black or White spots or Bright spots or Color spots on LCD (Display only)	2.1 White and black or color spots on display $\cong 0.25\text{mm}$, no more than two spots. 2.2 Densely spaced: No more than three spots within 10mm.		1.5												
03	Light on test	Line Defect	Not allowed	0.65												
04	Mura	There should not be non-uniformity through 5% transparency of filter. (Judged by limit sample if it has been defined)		1.5												
05	Tiny bright dot		Visible through 5% ND filter or limited	1.5												
06	LCD Panel black spots, white spots, contamination (non - display)	Line type: (As following drawing) 	<table border="1"> <thead> <tr> <th>Length(mm)</th> <th>Width(mm)</th> <th>Acceptable Q'ty</th> </tr> </thead> <tbody> <tr> <td>---</td> <td>$W \cong 0.03$</td> <td>Accept no dense</td> </tr> <tr> <td>$L \cong 5.0$</td> <td>$0.03 < W \cong 0.05$</td> <td>2</td> </tr> <tr> <td>---</td> <td>$0.05 < W$</td> <td>Rejection</td> </tr> </tbody> </table>	Length(mm)	Width(mm)	Acceptable Q'ty	---	$W \cong 0.03$	Accept no dense	$L \cong 5.0$	$0.03 < W \cong 0.05$	2	---	$0.05 < W$	Rejection	1.5
		Length(mm)	Width(mm)	Acceptable Q'ty												
---	$W \cong 0.03$	Accept no dense														
$L \cong 5.0$	$0.03 < W \cong 0.05$	2														
---	$0.05 < W$	Rejection														
Round type: As following drawing  $D = (a+b) / 2$	<table border="1"> <thead> <tr> <th>Size(mm)</th> <th>Acceptable Q'ty</th> </tr> </thead> <tbody> <tr> <td>$D \cong 0.10$</td> <td>Accept no dense</td> </tr> <tr> <td>$0.10 < D \cong 0.25$</td> <td>2</td> </tr> <tr> <td>$0.25 < D$</td> <td>0</td> </tr> </tbody> </table>	Size(mm)	Acceptable Q'ty	$D \cong 0.10$	Accept no dense	$0.10 < D \cong 0.25$	2	$0.25 < D$	0							
Size(mm)	Acceptable Q'ty															
$D \cong 0.10$	Accept no dense															
$0.10 < D \cong 0.25$	2															
$0.25 < D$	0															
07	Polarizer bubbles	If bubbles are visible, judge using black spot Specifications,	<table border="1"> <thead> <tr> <th>Size D(mm)</th> <th>Acceptable Q'ty</th> </tr> </thead> <tbody> <tr> <td>$D \cong 0.10$</td> <td>Accept no dense</td> </tr> <tr> <td>$0.10 < D \cong 0.20$</td> <td>2</td> </tr> <tr> <td>$0.20 < D \cong 0.25$</td> <td>1</td> </tr> <tr> <td>$0.25 < D$</td> <td>0</td> </tr> </tbody> </table>	Size D(mm)	Acceptable Q'ty	$D \cong 0.10$	Accept no dense	$0.10 < D \cong 0.20$	2	$0.20 < D \cong 0.25$	1	$0.25 < D$	0	1.5		
Size D(mm)	Acceptable Q'ty															
$D \cong 0.10$	Accept no dense															
$0.10 < D \cong 0.20$	2															
$0.20 < D \cong 0.25$	1															
$0.25 < D$	0															

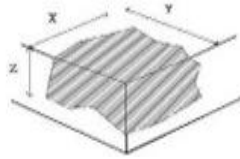
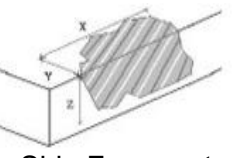
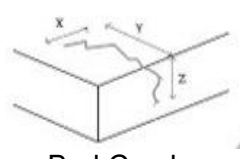

Shenzhen Mingqi Photoelectric Co., Ltd.

NO	Item	Criterion	AQL	
08	Chipped glass	 Corner Fragment	Length $X < 0.5\text{mm}$ Width $Y < 0.5\text{ mm}$ Thickness $Z \cong \text{Glass thickness}$ (Sealant area could not be broken)	1.5
		 Side Fragment	Length $X < 1.0\text{ mm}$ Width $Y < 0.5\text{ mm}$ Thickness $Z \cong \text{Glass thickness}$ (Sealant area could not be broken)	1.5
		 Bad Crack	NOT ALLOWED	0.65
09	Backlight elements	Illumination source flickers when lit.	0.65	
		Spots or scratches that appear when lit must be judged. Using LCD spot, lines and contamination standards.	1.5	
		Backlight doesn't light or color is wrong	0.65	
10	Bezel	Bezel must comply with product specifications.	0.65	
11	FPC	FPC terminal damage $\cong 1/2$ FPC terminal width and can not affect the function , we judge accept.	1.5	
		FPC alignment hole damage $\cong 1/2$ alignment area and can not affect the function , we judge accept.	0.65	
12	Soldering	No cold solder joints, missing solder connections, oxidation or icicle.	1.5	
		No short circuits in components on FPC	0.65	

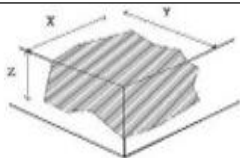
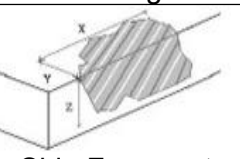
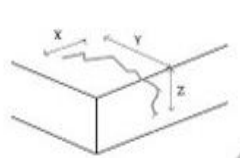
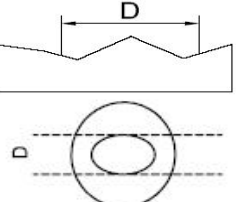
No	Item	Description	AQL								
13	Touch Panel Chipped glass	 Corner Fragment	Length $X < 0.5\text{mm}$ Width $Y < 0.5\text{ mm}$ Tickness $Z \cong$ Glass thickness (Sealant area could not be broken)	1.5							
		 Side Fragment	Length $X < 1.0\text{ mm}$ Width $Y < 0.5\text{ mm}$ Tickness $Z \cong$ Glass thickness (Sealant area could not be broken)	1.5							
		 Bad Crack	NOT ALLOWED	0.65							
14	Touch Panel(Fish eye、dent、bubble on film and off the paint)	 <table border="1" style="margin-left: auto; margin-right: auto;"> <thead> <tr> <th>Size(mm)</th> <th>Acceptable Q'ty</th> </tr> </thead> <tbody> <tr> <td>$D \cong 0.15$</td> <td>Accept no dense</td> </tr> <tr> <td>$0.15 < D \cong 0.25$</td> <td>2</td> </tr> <tr> <td>$0.25 < D$</td> <td>0</td> </tr> </tbody> </table>	Size(mm)	Acceptable Q'ty	$D \cong 0.15$	Accept no dense	$0.15 < D \cong 0.25$	2	$0.25 < D$	0	1.5
Size(mm)	Acceptable Q'ty										
$D \cong 0.15$	Accept no dense										
$0.15 < D \cong 0.25$	2										
$0.25 < D$	0										
15	Touch Panel Newton ring	Newton ring dimension $\cong 1/2$ touch panel area and not affect font and line distortion($\cong 2.5\%$) , it is acceptable.	1.5								
16	General appearance	13.1 Pin type must match type in specification sheet. 13.2 LCD pin loose or missing pins. 13.3 Product packaging must the same as specified on packaging specification sheet. 13.4 Product dimension and structure must conform to product specification sheet.	0.65								

[Note1] The definition of Bright dot

- (1)The defective area of the dot is larger than 50% of one sub-pixel area.
- (2)The bright dot shall be visible under ND-Filter 5%as following.

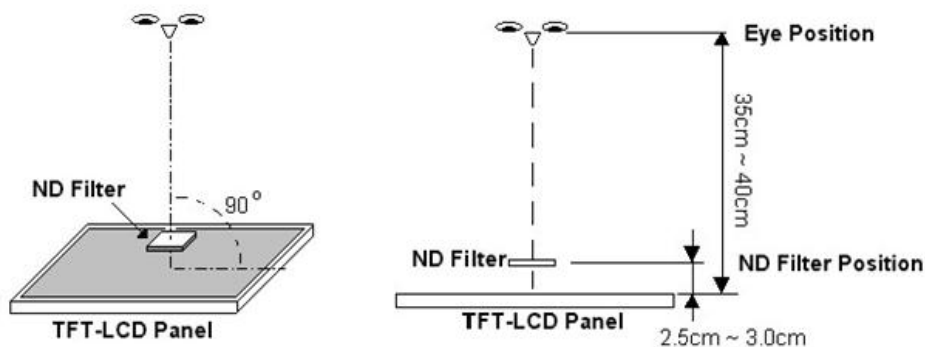



Shenzhen Mingqi Photoelectric Co., Ltd.

5. PRECAUTIONS FOR USING LCD MODULES

5.1 Handling Precautions

5.1.1 The display panel is made of glass and polarizer. As glass is fragile. It tends to become or chipped during handling especially on the edges. Please avoid dropping or jarring. Do not subject it to a mechanical shock by dropping it or impact.

5.1.2 If the display panel is damaged and the liquid crystal substance leaks out, be sure not to get any in your mouth. If the substance contacts your skin or clothes, wash it off using soap and water.

5.1.3 Do not apply excessive force to the display surface or the adjoining areas since this may cause the color tone to vary. Do not touch the display with bare hands. This will stain the display area and degraded insulation between terminals (some cosmetics are determined to the polarizer).

5.1.4 The polarizer covering the display surface of the LCD module is soft and easily scratched. Handle this polarizer carefully. Do not touch, push or rub the exposed polarizers with anything harder than an HB pencil lead (glass, tweezers, etc.). Do not put or attach anything on the display area to avoid leaving marks on it. Condensation on the surface and contact with terminals due to cold will damage, stain or dirty the polarizer. After products are tested at low temperature they must be warmed up in a container before coming in to contact with room temperature air.

5.1.5 If the display surface becomes contaminated, breathe on the surface and gently wipe it with a soft dry cloth. If it is heavily contaminated, moisten cloth with one of the following solvents

- Isopropyl alcohol
- Ethyl alcohol

Do not scrub hard to avoid damaging the display surface.

5.1.6 Solvents other than those above-mentioned may damage the polarizer. Especially, do not use the following.

- Water
- Ketone
- Aromatic solvents

Wipe off saliva or water drops immediately, contact with water over a long period of time may cause deformation or color fading. Avoid contact with oil and fats.

5.1.7 Exercise care to minimize corrosion of the electrode. Corrosion of the electrodes is accelerated by water droplets, moisture condensation or a current flow in a high-humidity environment.

5.1.8 Install the LCD Module by using the mounting holes. When mounting the LCD module make sure it is free of twisting, warping and distortion. In particular, do not forcibly pull or bend the I/O cable or the backlight cable.

5.1.9 Do not attempt to disassemble or process the LCD module.

5.1.10 NC terminal should be open. Do not connect anything.

5.1.11 If the logic circuit power is off, do not apply the input signals.

5.1.12 Electro-Static Discharge Control, Since this module uses a CMOS LSI, the same careful attention should be paid to electrostatic discharge as for an ordinary CMOS IC. To prevent destruction of the elements by static electricity, be careful to maintain an optimum work environment.

(1) Before removing LCM from its packing case or incorporating it into a set, be sure the module and your body have the same electric potential. Be sure to ground the body when handling the LCD modules.

(2) Tools required for assembling, such as soldering irons, must be properly grounded. Make certain the AC power source for the soldering iron does not leak. When using an electric screwdriver to attach LCM, the screwdriver should be of ground potentiality to minimize as much as possible any transmission of electromagnetic waves produced sparks coming from the commutator of the motor.

(3) To reduce the amount of static electricity generated, do not conduct assembling and other work under dry conditions. To reduce the generation of static electricity be careful that the air in the work is not too dry. A relative humidity of 50%-60% is recommended. As far as possible make the electric potential of your work clothes and that of the work bench the ground potential.

(4) The LCD module is coated with a film to protect the display surface. Exercise care when peeling off this protective film since static electricity may be generated.

5.1.13 Since LCM has been assembled and adjusted with a high degree of precision, avoid applying excessive shocks to the module or making any alterations or modifications to it.

- (1) Do not alter, modify or change the shape of the tab on the metal frame.

Shenzhen Mingqi Photoelectric Co., Ltd.

- (2) Do not make extra holes on the printed circuit board, modify its shape or change the positions of components to be attached.
- (3) Do not damage or modify the pattern writing on the printed circuit board.
- (4) Absolutely do not modify the zebra rubber strip (conductive rubber) or heat seal connector.
- (5) Except for soldering the interface, do not make any alterations or modifications with a soldering iron.
- (6) Do not drop, bend or twist the LCM

5.2 Handling precaution for LCM

5.2.1 LCM is easy to be damaged. Please note below and be careful for handling.

5.2.2 Correct handling:



As above picture, please handle with anti-static gloves around LCM edges.



Please don't touch IC directly.

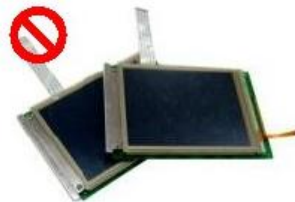

Please don't stack LCM.



Please don't hold the surface of panel



Please don't stretch interface of output, such as FPC cable.



Please don't hold the surface of IC.



Please don't operate with sharp stick such as pens.

5.3 Storage Precautions

5.3.1 When storing the LCD modules, the following precaution are necessary.

5.3.1.1 Store them in a sealed polyethylene bag. If properly sealed, there is no need for the

5.3.1.2 Store them in a dark place. Do not expose to sunlight or fluorescent light, keep the temperature between 0°C and 35°C, and keep the relative humidity between 40%RH and 60%RH.



Shenzhen Mingqi Photoelectric Co., Ltd.

5.3.1.3 The polarizer surface should not come in contact with any other objects (We advise you to store them in the anti-static electricity container in which they were shipped).

5.3.2 Transportation Precautions

5.3.2.1 During shipment, please handle with care. The packaging bag can not be broken, step on trap. Packaging Carton layer height can not be over two meters.

5.3.2.2 The transportation process should pay attention to the waterproof and moisture-proof measures. Product can not be watering. Ethylene sealed bags can not be unsealed.

5.3.3 Others

5.3.3.1 Liquid crystals solidify under low temperature (below the storage temperature range) leading to defective orientation or the generation of air bubbles (black or white). Air bubbles may also be generated if the module is subject to a low temperature.

5.3.3.2 If the LCD modules have been operating for a long time showing the same display patterns, the display patterns may remain on the screen as ghost images and a slight contrast irregularity may also appear. A normal operating status can be regained by suspending use for some time. It should be noted that this phenomenon does not adversely affect performance reliability. Please do not use in one picture for a long time; If fixed for a long time, an unrecoverable ghost images will appear.

5.3.4 Precautions for Operation

5.3.4.1 Viewing angle varies with the change of liquid crystal driving voltage (VLCD). Adjust VLCD to show the best contrast.

5.3.4.2 It is an indispensable condition to drive LCD's within the specified voltage limit since the higher voltage then the limit cause the shorter LCD life. An electrochemical reaction due to direct current causes LCD's undesirable deterioration, so that the use of direct current drive should be avoided.

5.3.4.3 Response time will be extremely delayed at lower temperature than the operating temperature range and on the other hand at higher temperature LCD's show dark color in them. However those phenomena do not mean malfunction or out of order with LCD's, which will come back in the specified operating temperature.

5.3.4.4 If the display area is pushed hard during operation, the display will become abnormal. However, it will return to normal if it is turned off and then back on.

5.3.4.5 A slight dew depositing on terminals is a cause for electro-chemical reaction resulting in terminal open circuit. Usage under the maximum operating temperature, 50%RH or less is required.

5.3.4.6 Input logic voltage before apply analog high voltage such as LCD driving voltage when power on. Remove analog high voltage before logic voltage when power off the module. Input each signal after the positive/negative voltage becomes stable.

5.3.4.7 Please keep the temperature within the specified range for use and storage. Polarization degradation, bubble generation or polarizer peel-off may occur with high temperature and high humidity.

5.3.4.8 It is easy to cause image sticking while displaying the same pattern for very long time.

5.4 Safety

5.4.1 It is recommended to crush damaged or unnecessary LCDs into pieces and wash them off with solvents such as acetone and ethanol, which should later be burned.

5.4.2 If any liquid leaks out of a damaged glass cell and comes in contact with the hands, wash off thoroughly with soap and water.

5.5 Limited Warranty

Unless agreed between RZW and the customer, RZW will replace or repair any of its LCD modules and Touch Panel which are found to be functionally defective when inspected in accordance with RZW LCD acceptance standards (copies available upon request) for a period of one year from date of production. Cosmetic/visual defects must be returned to RZW within 90 days of shipment. Confirmation of such date shall be based on data code on product. The warranty liability of RZW limited to repair and/or replace on the terms set forth above. RZW will not be responsible for any subsequent or consequential events.



Shenzhen Mingqi Photoelectric Co., Ltd.

5.6 Return LCM under warranty

5.6.1 No warranty can be granted if the precautions stated above have been disregarded. The typical examples of violations are :

5.6.1.1 - Broken LCD glass and Touch Panel Chipped glass.

5.6.1.2- FPC eyelet is damaged or modified

5.6.1.3- FPC conductors damaged.

5.6.1.4- Circuit modified in any way, including addition of components.

5.6.1.5- FPC tampered with by grinding, engraving or painting varnish.

5.6.1.6- Soldering to or modifying the bezel in any manner.

6. Agreement items

Both sides should discuss together when the following problems happen.

6.1 There is any problem of standard of quality assurance, and both sides should think that must be modified.

6.2 There is any argument item which does not record in the standard of quality assurance.

6.3 Any other special problem.



11. Records Of Version

Version	Revise Date	Page	Content
00	2024-03-05	All	New released